

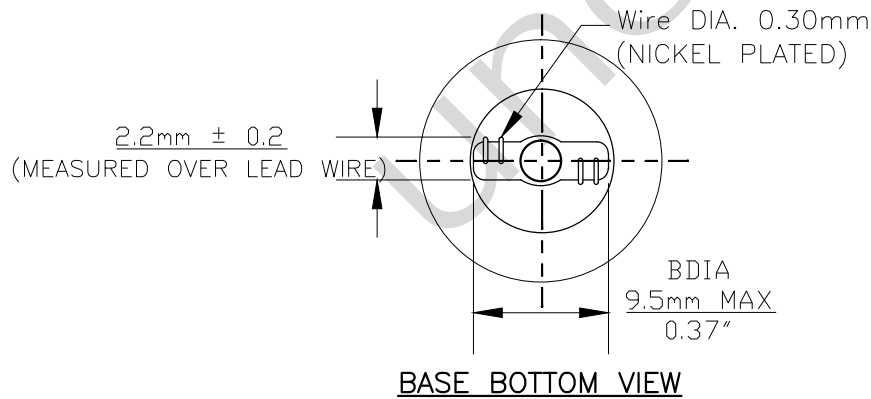

PART NO.	BASE TYPE	DESIGN VOLTS	DESIGN AMPS	MSCD	FILAMENT TYPE	AVERAGE LIFE HOURS	REVISIONS			
							REV #	DESCRIPTION	DATE	APPROVED
917	Glass Wedge W2.1X9.5d (T-5)	12.0V	1.2±10%	10.0±15%	C-2R	1,200	1	ISSUED	03/24/2016	R.M.

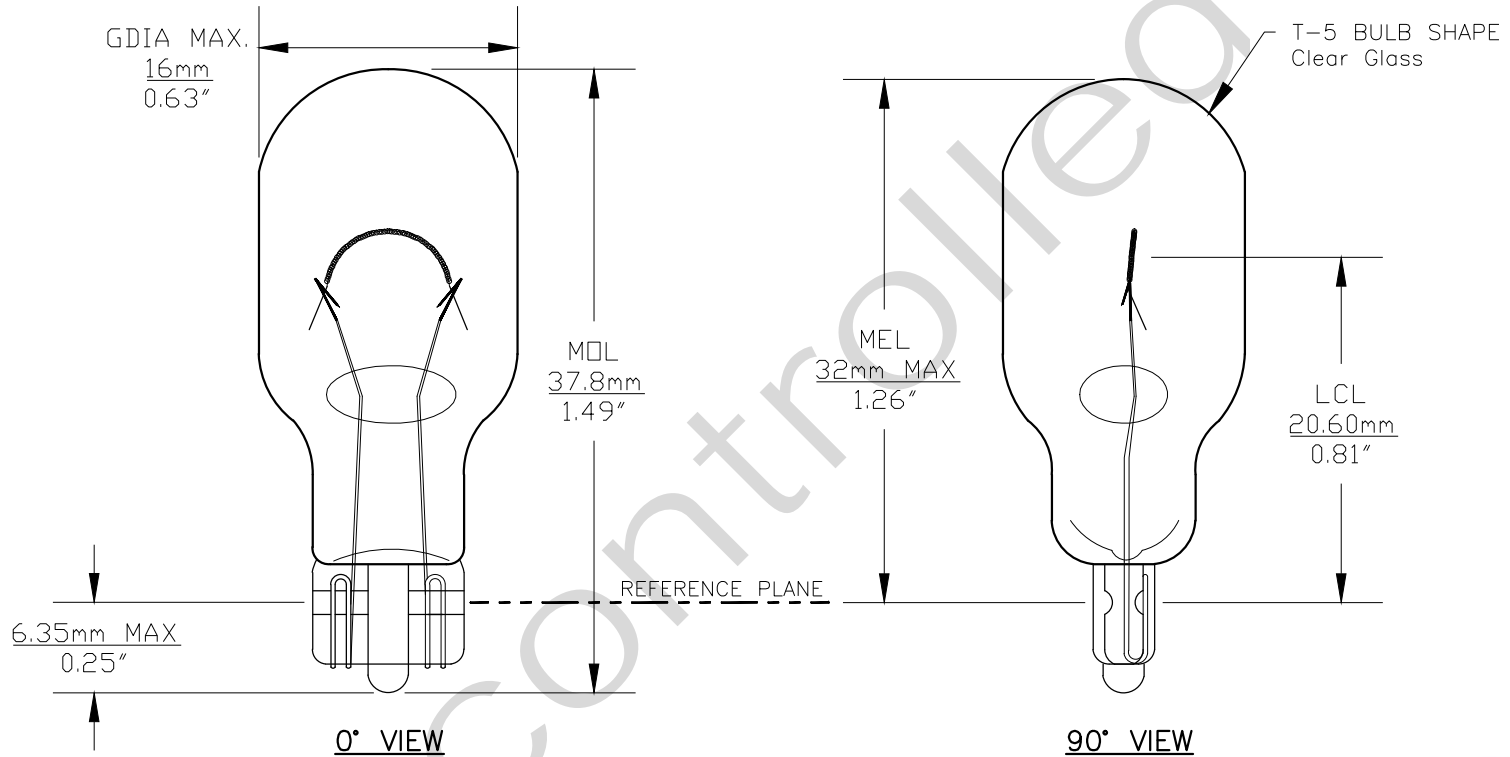

Note: Made according to SAE specifications



UNLESS OTHERWISE SPECIFIED: DIMENSIONS ARE IN INCHES TOLERANCES		CEC INDUSTRIES LTD	
DECIMALS .XX ± .05 .XXX ± .010 FRACTIONAL ±1/64	ANGULAR ± 0.5°	599 BOND STREET	LINCOLNSHIRE, IL 60069
DRAWN ROSE MEDINA	DATE 03/24/2016	TITLE LIGHT BULB NO. 917	
CHECKED	SIZE A	FSCM NO.	DWG NO. 917 REV 1
DESIGN	SCALE	PLOT SCALE	SHEET 1 OF 1
MATERIAL	FILE 917.pdf	DRAWING NOT TO SCALE	