

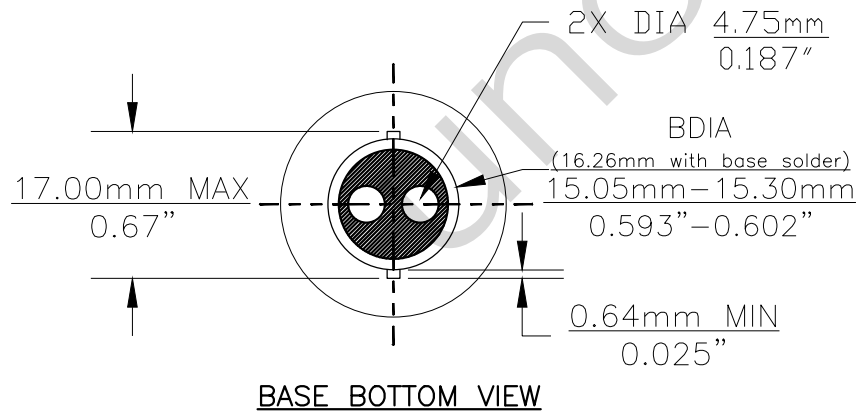

Since 1959

PART NO.	BASE TYPE	TEST VOLTS	DESIGN AMPS	MSCD	FILAMENT TYPE	AVERAGE LIFE HOURS	REVISIONS			
							REV #	DESCRIPTION	DATE	APPROVED
HIB2057 WM	D.C. INDEX BAY15d	12.8V 14V	2.10±5% 0.48±8%	32±10% 2±12%	C-6 C-6	1200 5000	1	ISSUED	05/28/2019	R.M.

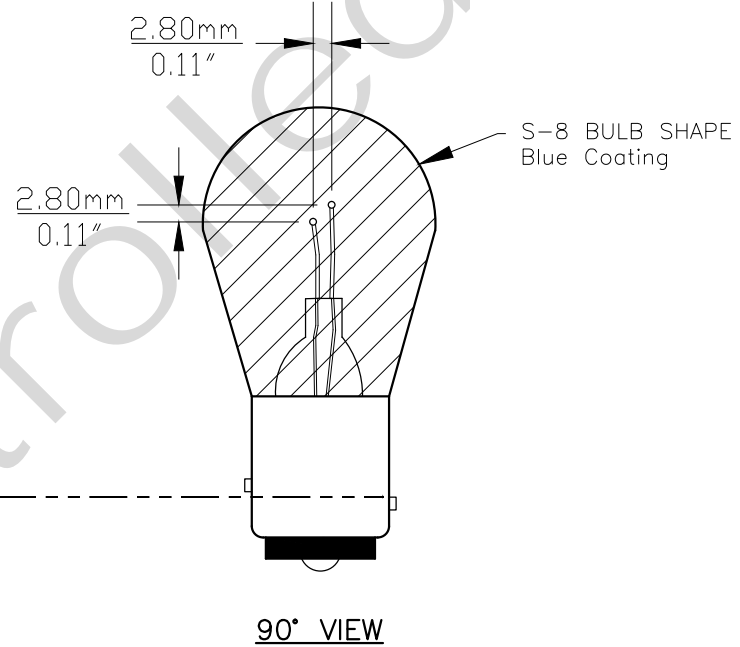
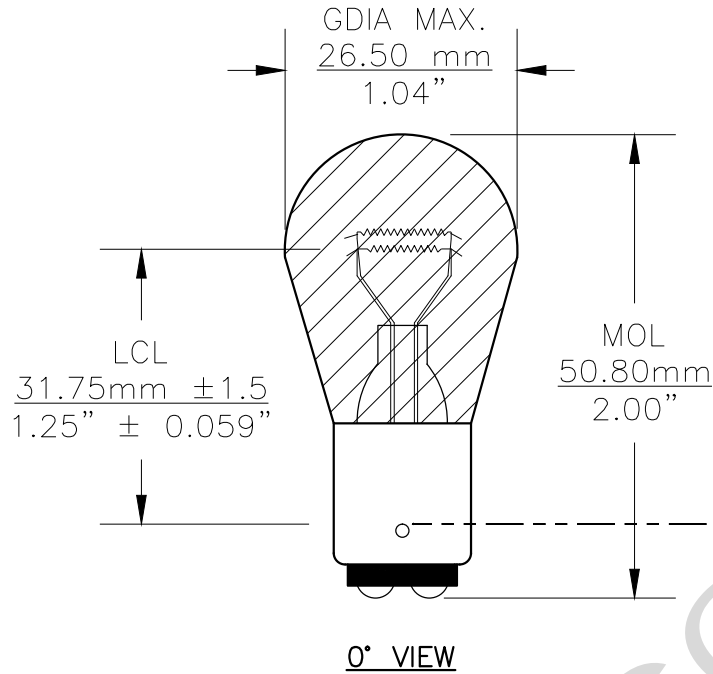

Note: Made according to SAE specifications

UNLESS OTHERWISE SPECIFIED: DIMENSIONS ARE IN INCHES TOLERANCES		CEC INDUSTRIES LTD			
DECIMALS	ANGULAR	599 BOND STREET		LINCOLNSHIRE, IL 60069	
.XX ± .05	± 0.5°	TITLE LIGHT BULB NO. HIB2057 WM			
.XXX ± .010		SCALE	FSCM NO.	DWG NO.	REV
FRACTIONAL	±1/64	A		HIB2057 WM	1
DRAWN ROSE MEDINA	DATE 05/28/2019	SCALE		PLOT SCALE	SHEET 1 OF 1
CHECKED		FILE		DRAWING NOT TO SCALE	
DESIGN		HIB2057WM.pdf			
MATERIAL					