

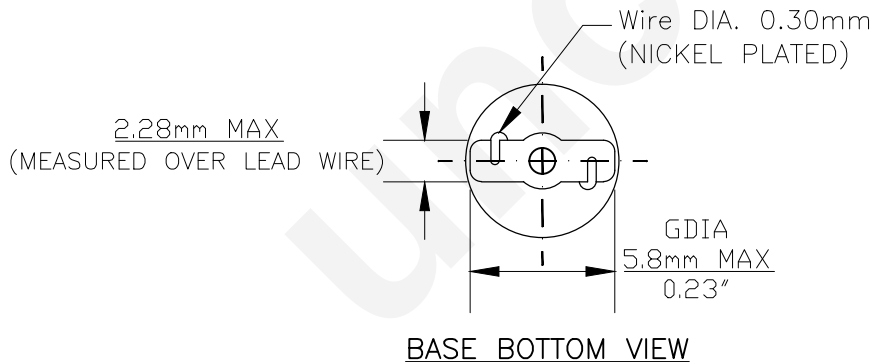

PART NO.	BASE TYPE	DESIGN VOLTS	DESIGN AMPS	MSCD	FILAMENT TYPE	AVERAGE LIFE HOURS	REVISIONS			
							REV #	DESCRIPTION	DATE	APPROVED
70	Sub-miniature Glass Wedge (T-1 3/4)	14.0V	0.15±15%	1.5±30%	C-2F	100	1	REDRAWN, ADDED 90° VIEW	06/05/2014	R.M.

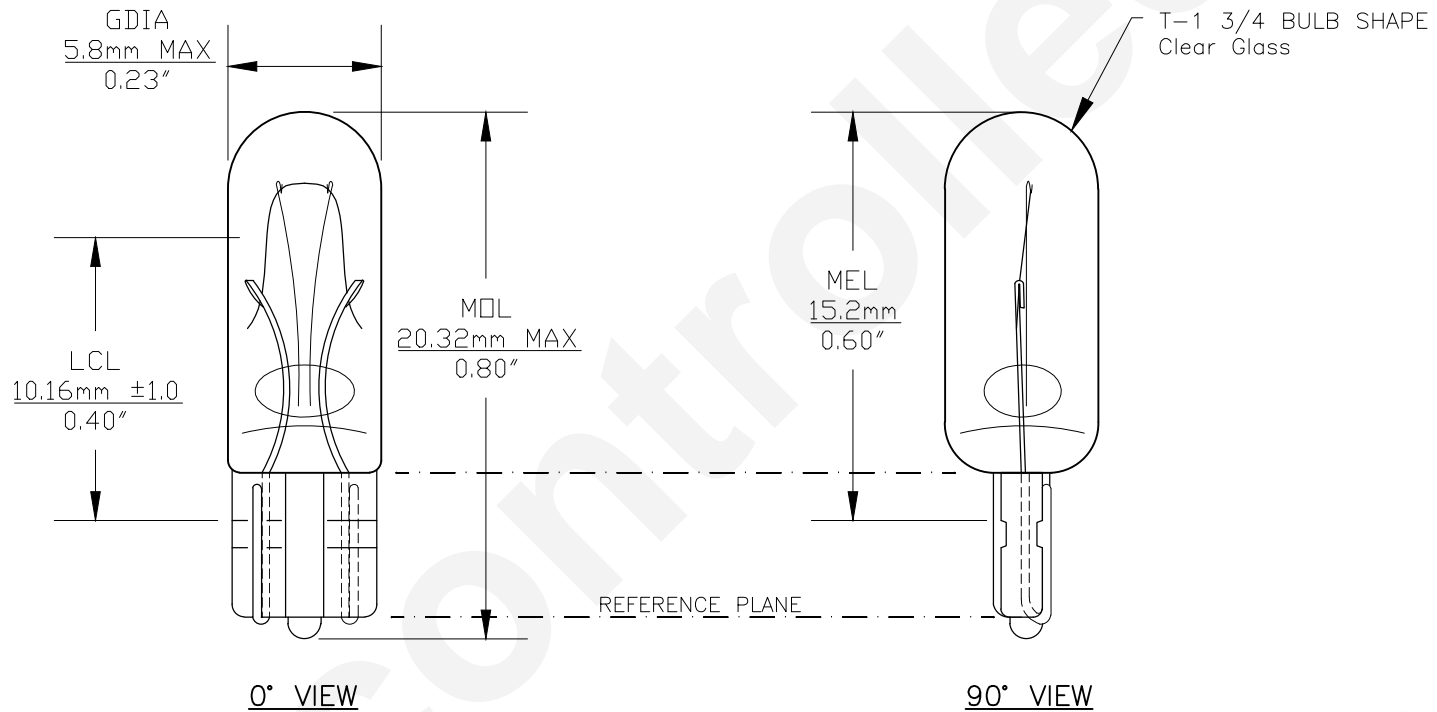

Note: Made according to SAE specifications



UNLESS OTHERWISE SPECIFIED: DIMENSIONS ARE IN INCHES TOLERANCES		CEC INDUSTRIES LTD			
DECIMALS	ANGULAR	599 BOND STREET		LINCOLNSHIRE, IL 60069	
.XX ± .05	± 0.5°	TITLE LIGHT BULB NO. 70			
.XXX ± .010		SIZE A	FSCM NO.	DWG NO. 70	REV 1
FRACTIONAL	±1/64	SCALE		PLOT SCALE	SHEET 1 OF 1
DRAWN D. CLARK		DATE 08/17/2005		MATERIAL	
CHECKED		FILE 70.pdf		DRAWING NOT TO SCALE	