

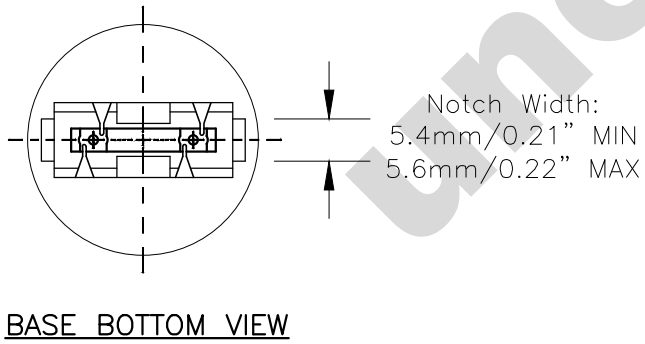

PART NO.	BASE TYPE	DESIGN VOLTS	DESIGN AMPS	MSCD	FILAMENT TYPE	AVERAGE LIFE HOURS
4156NALL	S.F. Plastic Wedge W2.5X16d	12.8V	2.10 ±5%	24±30%	C-6	4000

REVISIONS			
REV #	DESCRIPTION	DATE	APPROVED
1	REDRAWN TO UPDATE BASE	05/22/2014	R.M.

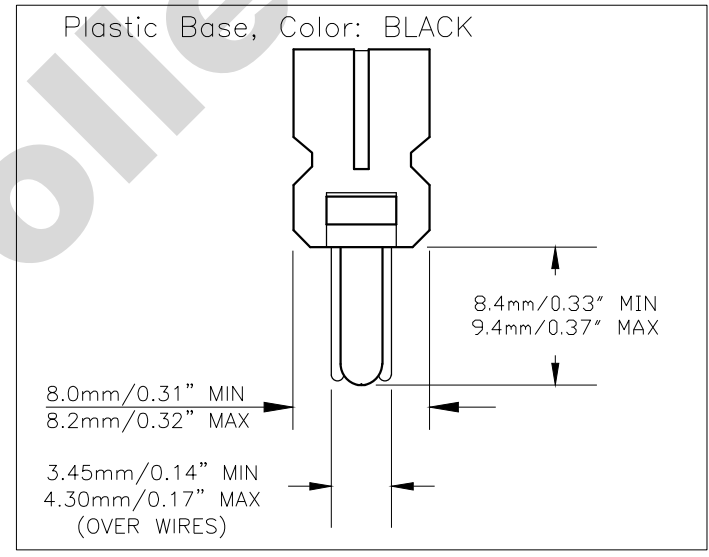
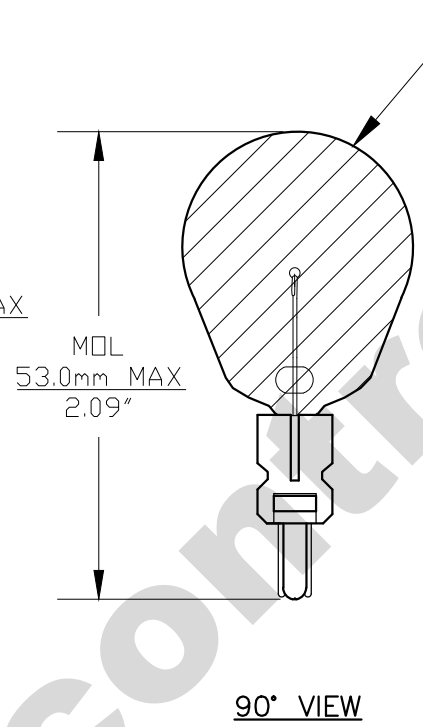
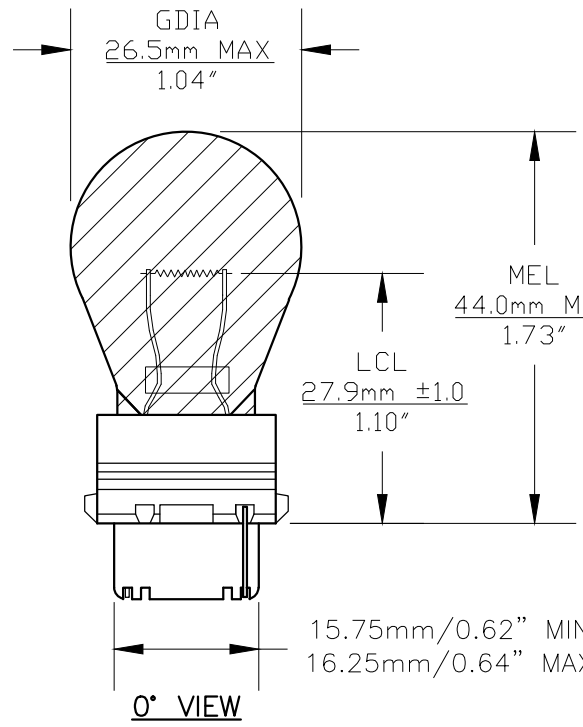

Note: Made according to SAE specifications



UNLESS OTHERWISE SPECIFIED: DIMENSIONS ARE IN INCHES TOLERANCES		CEC INDUSTRIES LTD	
DECIMALS	ANGULAR	599 BOND STREET	LINCOLNSHIRE, IL 60069
.XX ± .05	± 0.5°		
.XXX ± .010			
FRACTIONAL	±1/64		
DRAWN D. CLARK	DATE 12/20/2004	TITLE LIGHT BULB NO. 4156NALL	
CHECKED	SIZE A	FSCM NO.	DWG NO. 4156NALL
DESIGN	SCALE	PLOT SCALE	REV 1
MATERIAL	FILE 4156NALL.pdf	SHEET 1 OF 1	DRAWING NOT TO SCALE