

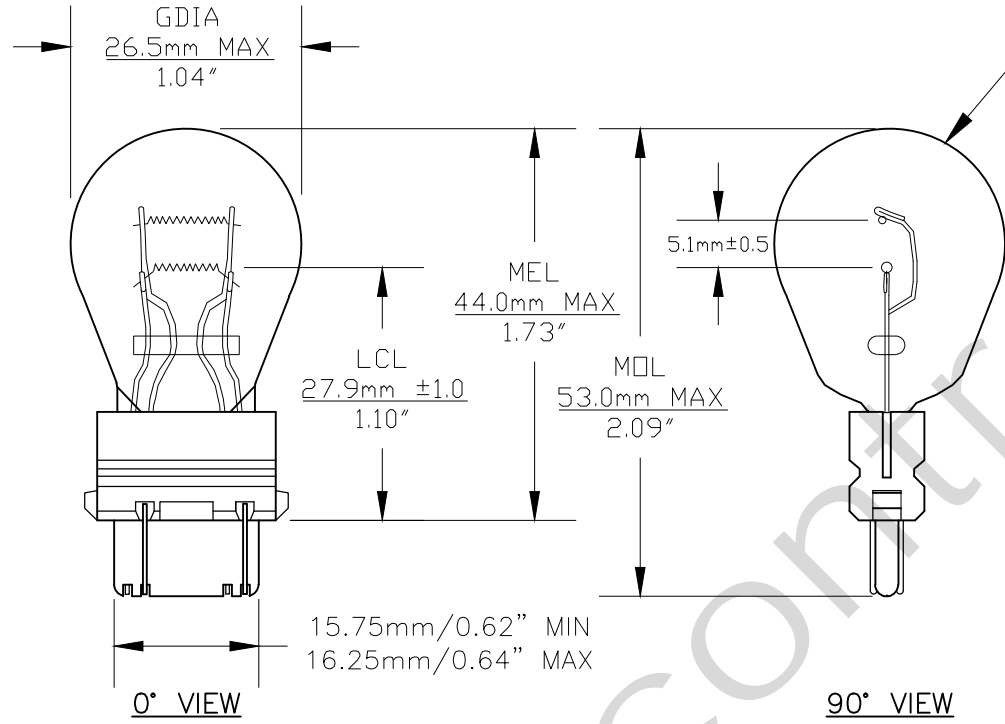

PART NO.	BASE TYPE	DESIGN VOLTS	DESIGN AMPS	MSCD	FILAMENT TYPE	AVERAGE LIFE HOURS
3457	D.F. Plastic Wedge W2.5X16q	12.8V 14.0V	2.23±5% 0.59±8%	40±10% 3±12%	C-6 C-6	400 5000

REVISIONS			
REV #	DESCRIPTION	DATE	APPROVED
1	REDRAWN	04/09/2007	D.C.
2	REDRAWN TO ADD MORE VIEWS	10/21/2014	R.M.
3	ADDED FILAMENT DISTANCE DIMENSIONS	10/04/2018	R.M.
4	ADDED BASE MATERIAL	03/05/2020	R.M.



S-8 BULB SHAPE
Natural Amber Glass

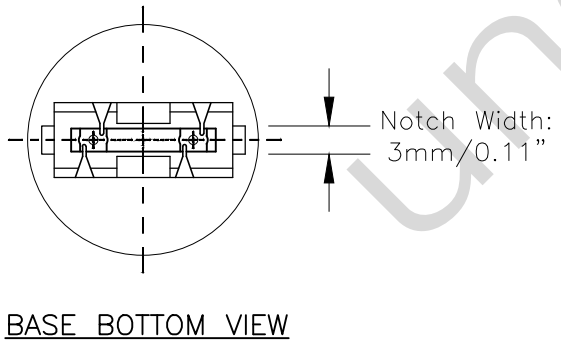
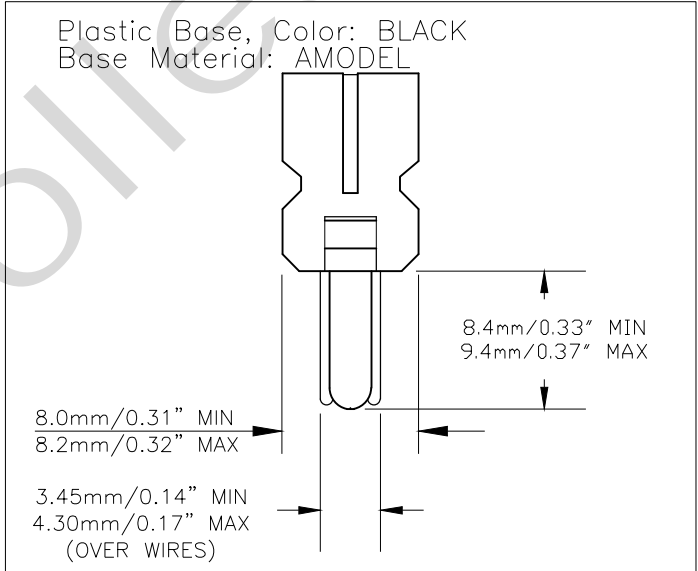

Note: Made according to SAE specifications



UNLESS OTHERWISE SPECIFIED: DIMENSIONS ARE IN INCHES TOLERANCES		CEC INDUSTRIES LTD	
DECIMALS	ANGULAR	599 BOND STREET LINCOLNSHIRE, IL 60069	
.XX ± .05	± 0.5°	TITLE LIGHT BULB NO. 3457	
.XXX ± .010		SIZE A	REV 4
FRACTIONAL	±1/64	FSCM NO.	DWG NO. 3457
DRAWN ELIZABETH SONANES	DATE 02/20/2001	SCALE	SHEET 1 OF 1
CHECKED		PLOT SCALE	DRAWING NOT TO SCALE
DESIGN		FILE 3457.pdf	
MATERIAL			