

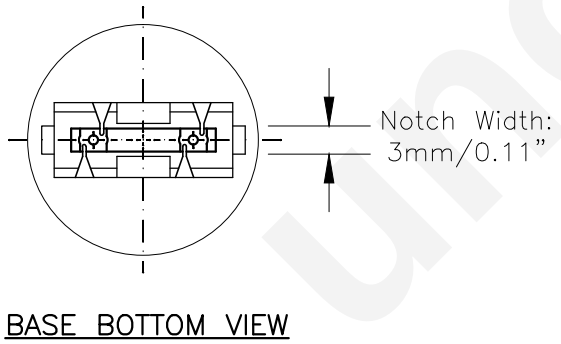

PART NO.	BASE TYPE	DESIGN VOLTS	DESIGN AMPS	MSCD	FILAMENT TYPE	AVERAGE LIFE HOURS	REVISIONS			
							REV #	DESCRIPTION	DATE	APPROVED
3057NA	D.F. Plastic Wedge W2.5X16q	12.8V 14.0V	2.10±5% 0.48±8%	24±30% 1.6±30%	C-6 C-6	1200 5000	1	ISSUED	06/27/2013	D.C.
							2	ADDED FILAMENT DISTANCE DIMENSIONS	10/04/2018	R.M.

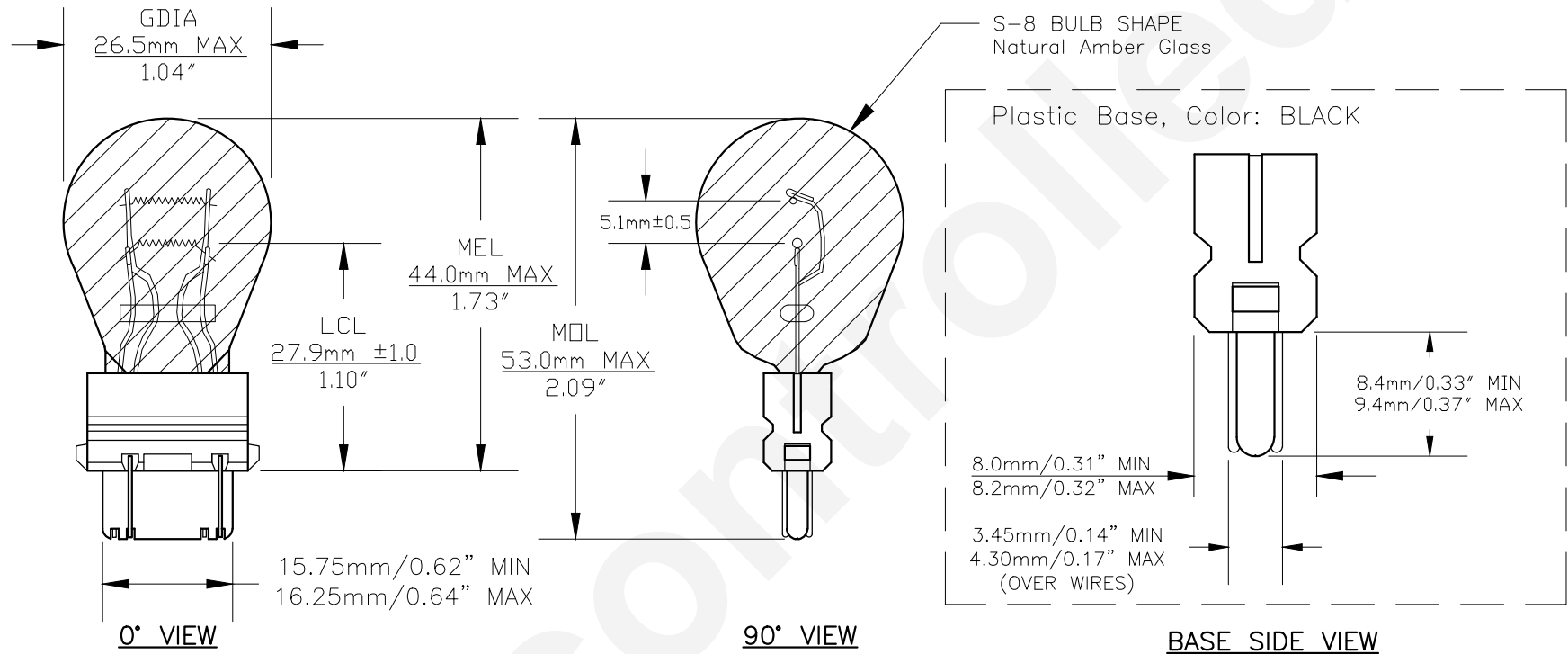

Note: Made according to SAE specifications



UNLESS OTHERWISE SPECIFIED: DIMENSIONS ARE IN INCHES TOLERANCES		CEC INDUSTRIES LTD			
DECIMALS .XX ± .05		599 BOND STREET		LINCOLNSHIRE, IL 60069	
ANGULAR .XXX ± .010		TITLE LIGHT BULB NO. 3057NA			
FRACTIONAL ±1/64		DATE 06/27/2013	SIZE A	DWG NO. 3057NA	REV 2
DRAWN D. C.		SCALE	PLOT SCALE	SHEET 1 OF 1	
CHECKED		FILE 3057NA.pdf	DRAWING NOT TO SCALE		