

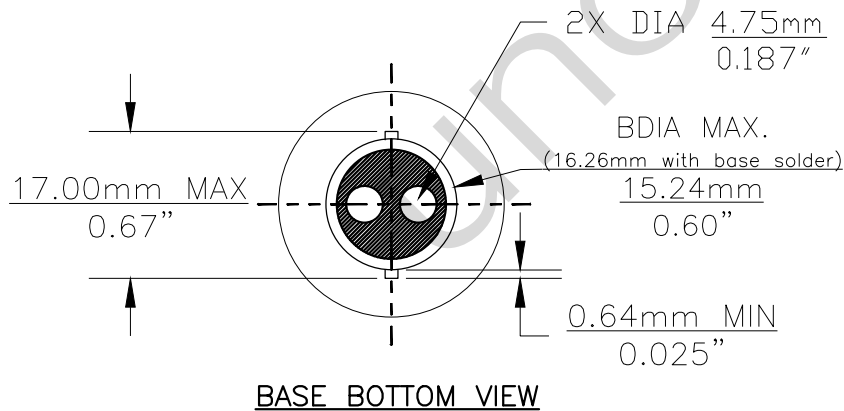

PART NO.	BASE TYPE	DESIGN VOLTS	DESIGN AMPS	MSCD	FILAMENT TYPE	AVERAGE LIFE HOURS	REVISIONS			
							REV #	DESCRIPTION	DATE	APPROVED
2397	D.C. INDEX BAY15d	12.8V 14.0V	2.2± 5% 0.48± 8%	40±10% 2±12%	C-6 C-6	400 2,000	1	ISSUED	05/24/2011	D.C.
							2	LCL TOLERANCE	01/23/2013	D.C.
							3	REDRAWN FOR ADDITIONAL VIEW	10/22/2014	R.M.

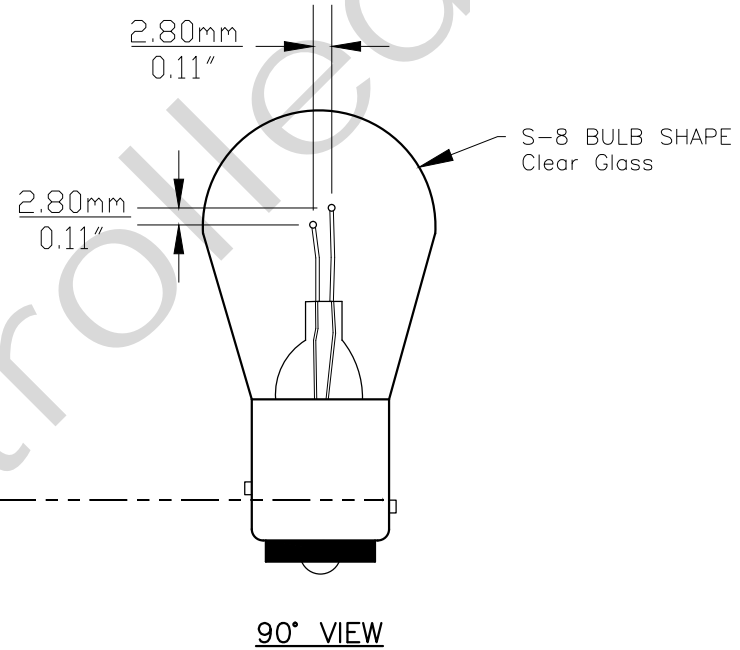
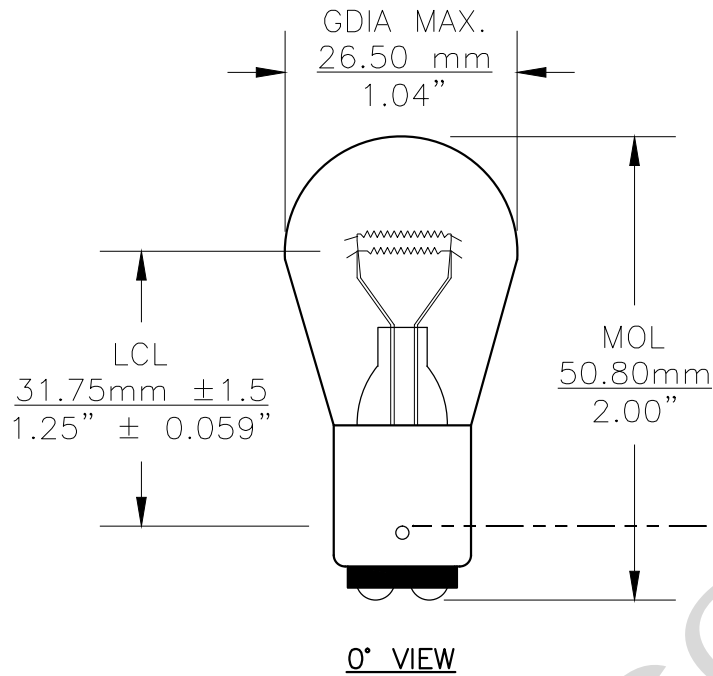

Note: Made according to SAE specifications

UNLESS OTHERWISE SPECIFIED: DIMENSIONS ARE IN INCHES TOLERANCES		CEC INDUSTRIES LTD			
DECIMALS .XX ± .05 .XXX ± .010 FRACTIONAL ± 1/64		ANGULAR ± 0.5°		599 BOND STREET LINCOLNSHIRE, IL 60069	
DRAWN D.C.	DATE 05/24/2011	TITLE LIGHT BULB NO. 2397			
CHECKED	SIZE A	FSCM NO.	DWG NO. 2397	REV 3	
DESIGN	SCALE	PLOT SCALE	SHEET 1 OF 1		
MATERIAL	FILE 2397.pdf	DRAWING NOT TO SCALE			