

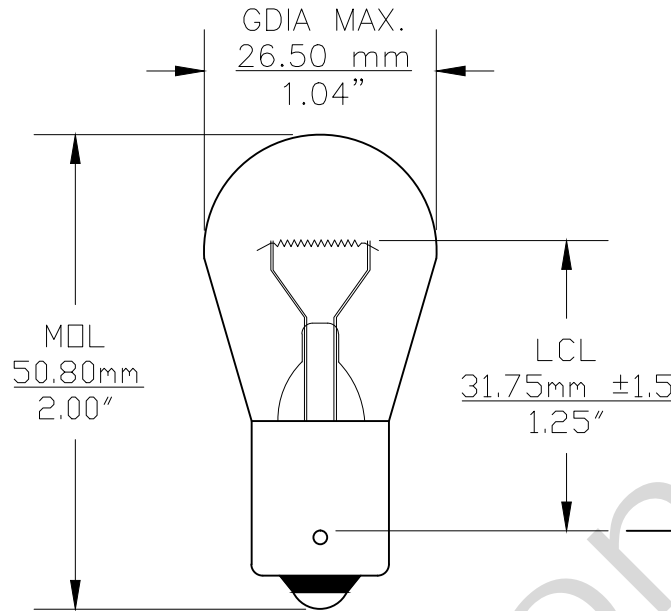

| PART NO. | BASE TYPE | DESIGN VOLTS | DESIGN AMPS | MSCD | FILAMENT TYPE | AVERAGE LIFE HOURS |
|----------|----------------------|--------------|-------------|----------|---------------|--------------------|
| 199 | S.C. Bayonet (BA15s) | 12.8V | 2.25±5% | 32.0±10% | C-6 | 1200 |

| REVISIONS | | | |
|-----------|------------------------------|------------|----------|
| REV # | DESCRIPTION | DATE | APPROVED |
| 1 | ISSUED | 10/31/2002 | A.S. |
| 2 | ADDRESS CHANGE, EXTRA VIEW | 01/19/2006 | D.C. |
| 3 | TOLERANCE AMPS, MSCD UPDATED | 09/21/2009 | D.C. |
| 4 | REDRAWN FOR ADDITIONAL VIEW | 07/01/2014 | R.M. |
| 5 | REVISED BASE DIAMETER | 03/26/2019 | R.M. |



0° VIEW

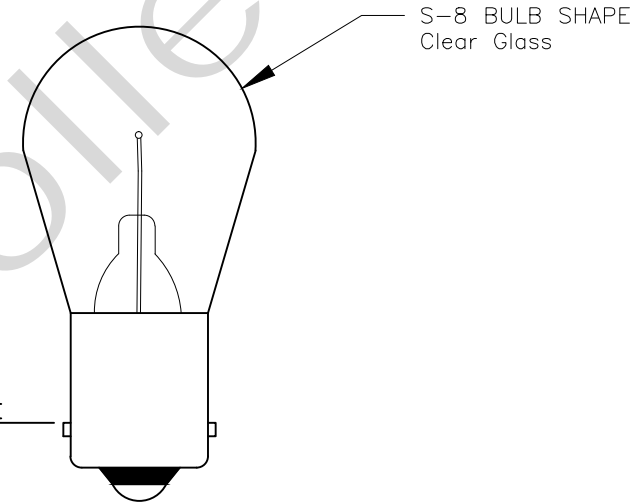

90° VIEW

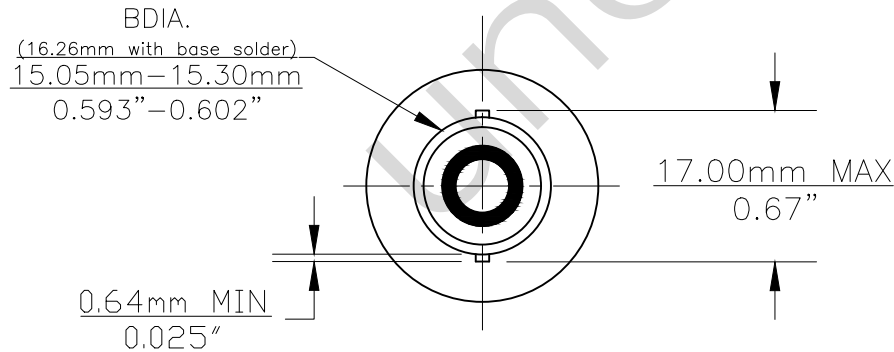

Note: Made according to SAE specifications



| | | | |
|---|-----------------|--|----------------------|
| UNLESS OTHERWISE SPECIFIED: DIMENSIONS ARE IN INCHES TOLERANCES | | CEC INDUSTRIES LTD | |
| DECIMALS | ANGULAR | 599 BOND STREET LINCOLNSHIRE, IL 60069 | |
| .XX ± .05 | ± 0.5° | TITLE LIGHT BULB NO. 199 | |
| .XXX ± .010 | | SIZE A | FSCM NO. DWG NO. 199 |
| FRACTIONAL | ±1/64 | SCALE | REV 5 |
| DRAWN ANNA SOLOVEYCHIK | DATE 10/31/2002 | PLOT SCALE | SHEET 1 OF 1 |
| CHECKED | | FILE 199.pdf | DRAWING NOT TO SCALE |