

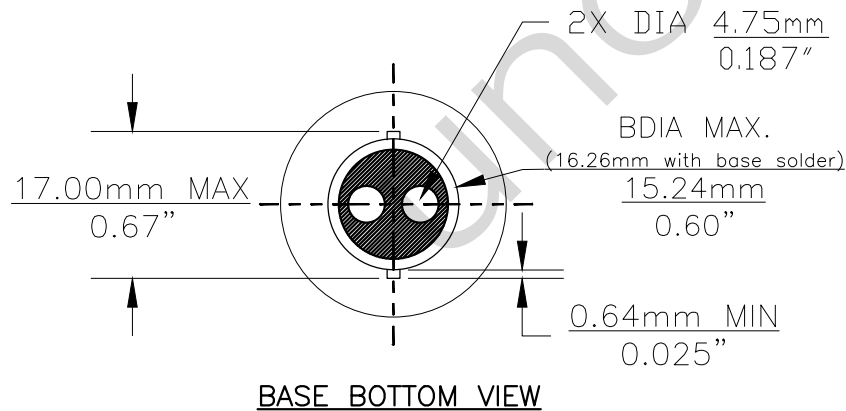

Since 1959

PART NO.	BASE TYPE	DESIGN VOLTS	DESIGN AMPS	MSCD	FILAMENT TYPE	AVERAGE LIFE HOURS	REVISIONS			
							REV #	DESCRIPTION	DATE	APPROVED
198	D.C. INDEX BAY15d	12.8V 14V	2.25±5% 0.68±8%	32±10% 3±12%	C-6 C-6	1200 5000	1	ISSUED	10/02/2007	D.C.
							2	AMPS .59	11/05/2007	D.C.
							3	REVISED MINOR AMPS FROM .59 TO .68	04/20/2018	R.M.

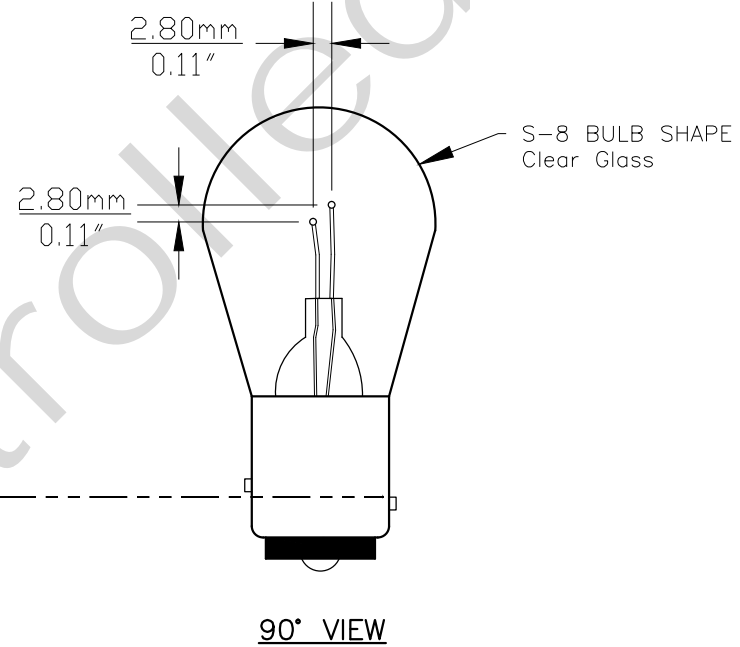
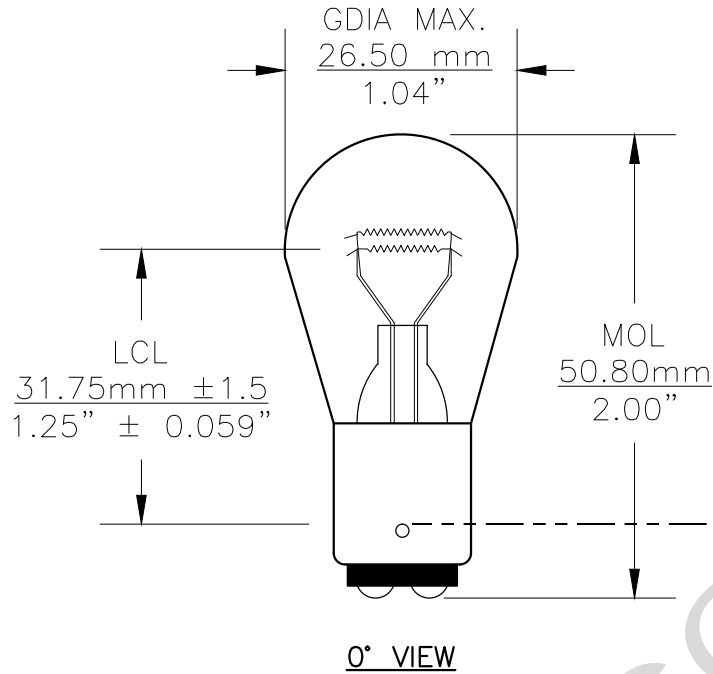

Note: Made according to SAE specifications

UNLESS OTHERWISE SPECIFIED: DIMENSIONS ARE IN INCHES TOLERANCES		CEC INDUSTRIES LTD			
DECIMALS .XX ± .05 .XXX ± .010 FRACTIONAL ±1/64		ANGULAR ± 0.5°		599 BOND STREET LINCOLNSHIRE, IL 60069	
DRAWN DENNIS CLARK	DATE 10/02/2007	TITLE LIGHT BULB NO. 198			
CHECKED	SIZE A	FSCM NO.	DWG NO. 198	REV 3	
DESIGN	SCALE	PLOT SCALE	SHEET 1 OF 1		
MATERIAL	FILE 198.pdf	DRAWING NOT TO SCALE			