

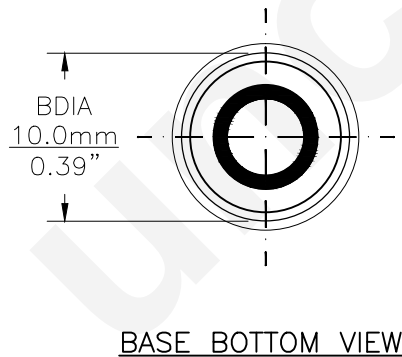

Since 1959

PART NO.	BASE TYPE	DESIGN VOLTS	DESIGN AMPS	MSCD	FILAMENT TYPE	AVERAGE LIFE HOURS	REVISIONS			
							REV #	DESCRIPTION	DATE	APPROVED
1832	Miniature Screw (E10)	48.0V	0.65±15%	0.5±30%	C-2F	3000				

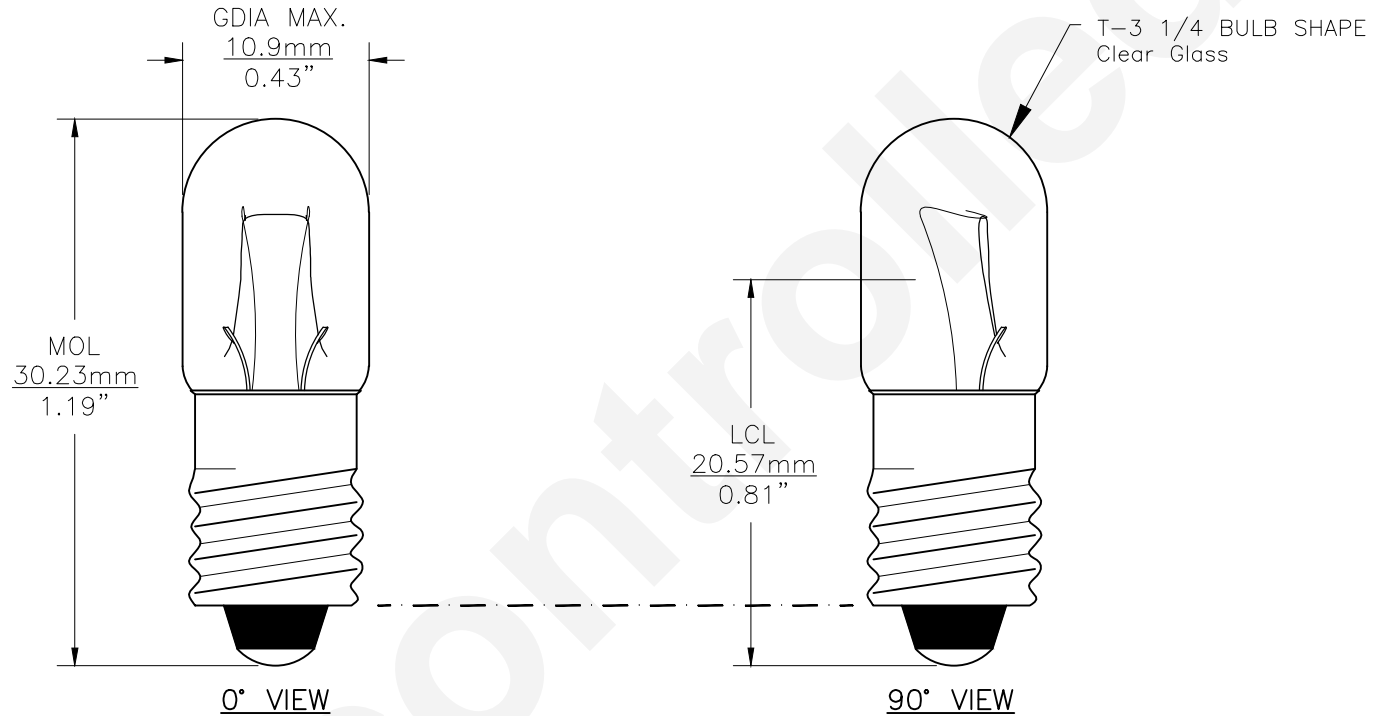

Note: Made according to SAE specifications



UNLESS OTHERWISE SPECIFIED: DIMENSIONS ARE IN INCHES TOLERANCES		CEC INDUSTRIES LTD			
DECIMALS .XX ± .05		ANGULAR ± 0.5°		599 BOND STREET LINCOLNSHIRE, IL 60069	
.XXX ± .010		FRACTIONAL ± 1/64		TITLE LIGHT BULB NO. 1832	
DRAWN ROSE MEDINA	DATE 10/31/2014	SIZE A	FSCM NO.	DWG NO. 1832	REV
CHECKED	DESIGN	SCALE	PLOT SCALE	SHEET 1 OF 1	
MATERIAL	FILE 1832.pdf	DRAWING NOT TO SCALE			