

PART NO.	BASE TYPE	DESIGN VOLTS	DESIGN AMPS	MSCD	FILAMENT TYPE	AVERAGE LIFE HOURS
1823	MINIATURE SCREW (E10)	48	0.10 ± 10%	3.2 ± 20%	C-2F	1000

REVISIONS			
REV	DESCRIPTION	DATE	APPROVED
1	ISSUED	10/30/2008	D.C.

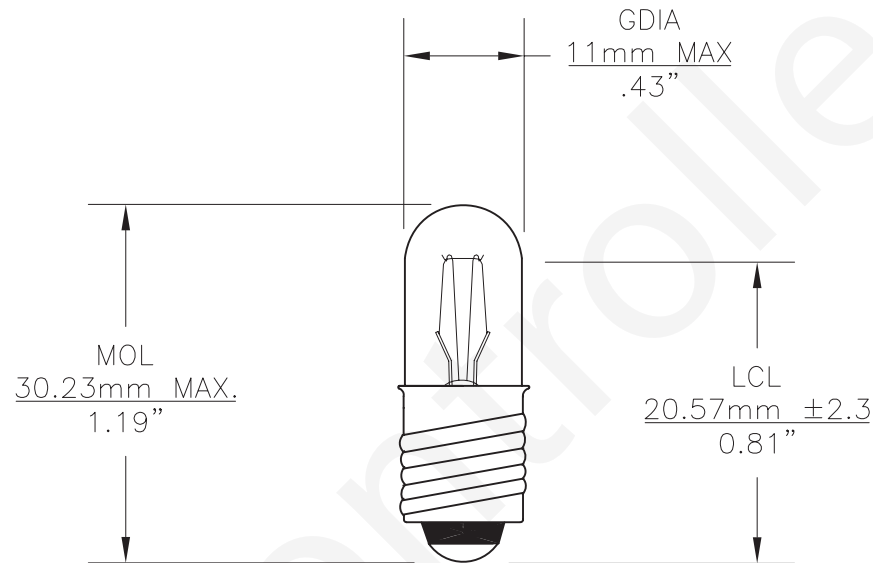

UNLESS OTHERWISE SPECIFIED:
DIMENSIONS ARE IN INCHES
TOLERANCES

DECIMALS	ANGULAR
.XX ± .05	± 0.5°
.XXX ± .010	
FRACTIONAL	±1/64

CEC INDUSTRIES LTD

599 BOND STREET

LINCOLNSHIRE, IL 60069

TITLE

LIGHT BULB NO. 1823

DRAWN	DATE
D.C.	10/30/2008

CHECKED	
---------	--

DESIGN	
--------	--

MATERIAL	
----------	--

SIZE	FSCM NO.	DWG NO.	REV
A		1823	1

SCALE	PLOT SCALE	SHEET 1 OF 1
-------	------------	--------------

FILE 1823.dwg	DO NOT SCALE DRAWING
---------------	----------------------