

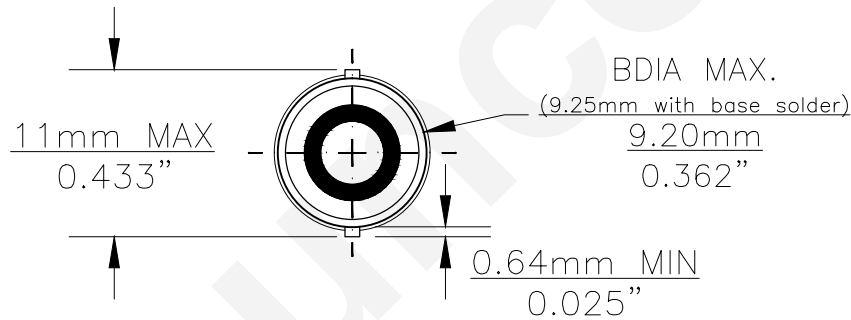

PART NO.	BASE TYPE	DESIGN VOLTS	DESIGN AMPS	MSCD	FILAMENT TYPE	AVERAGE LIFE HOURS	REVISIONS			
							REV #	DESCRIPTION	DATE	APPROVED
1816	MINIATURE BAYONET (BA9s)	13.0V	0.33±15%	3.0±20%	C-2V	1000	1	VERIFIED LAMP DIMENSIONS	10/04/2002	A.S.
							2	REDRAWN	12/20/2005	D.C.
							3	ADDED 0° VIEW & BASE BOTTOM VIEW	04/01/2016	R.M.

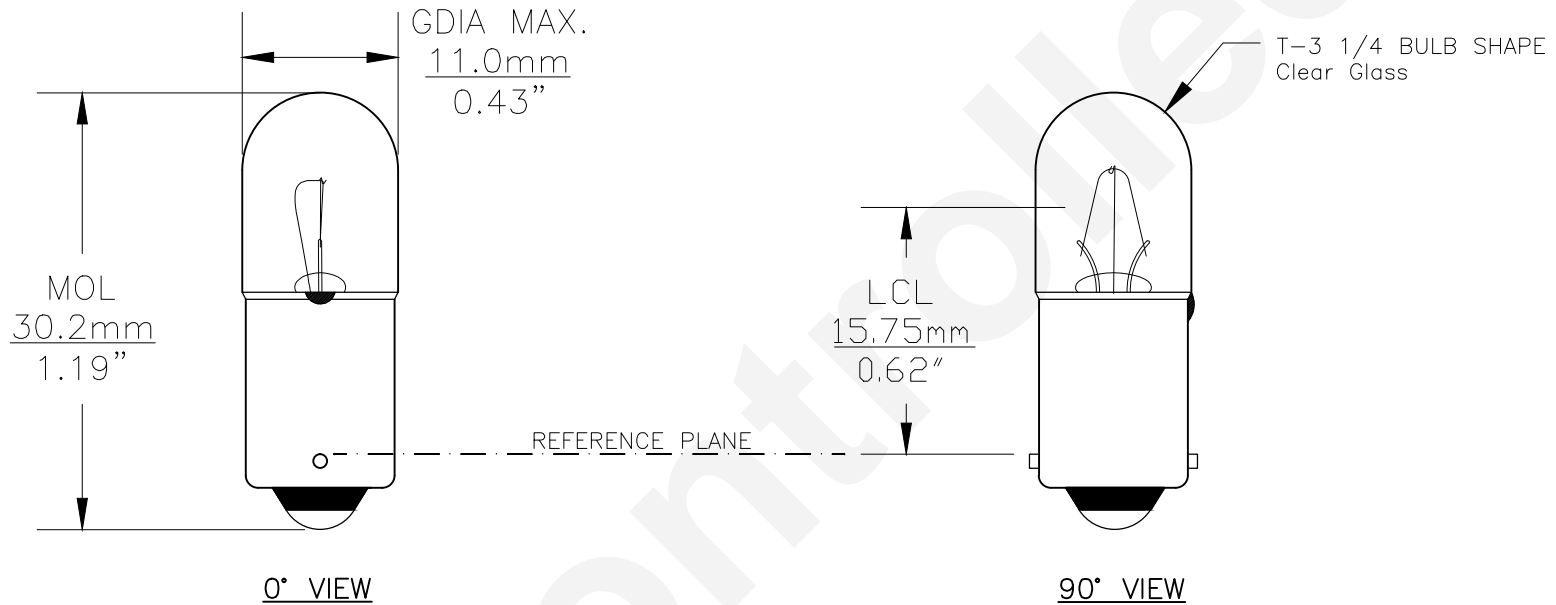

Note: Made according to SAE specifications

UNLESS OTHERWISE SPECIFIED: DIMENSIONS ARE IN INCHES TOLERANCES		CEC INDUSTRIES LTD			
DECIMALS .XX ± .05		599 BOND STREET		LINCOLNSHIRE, IL 60069	
ANGULAR .XXX ± .010		TITLE LIGHT BULB NO. 1816			
FRACTIONAL ±1/64		DATE 12/12/2001	SIZE A	DWG NO. 1816	REV 3
DRAWN ELIZABETH SONANES	CHECKED	DESIGN	SCALE	PLOT SCALE	SHEET 1 OF 1
MATERIAL	FILE 1816.pdf	DRAWING NOT TO SCALE			

BASE BOTTOM VIEW