

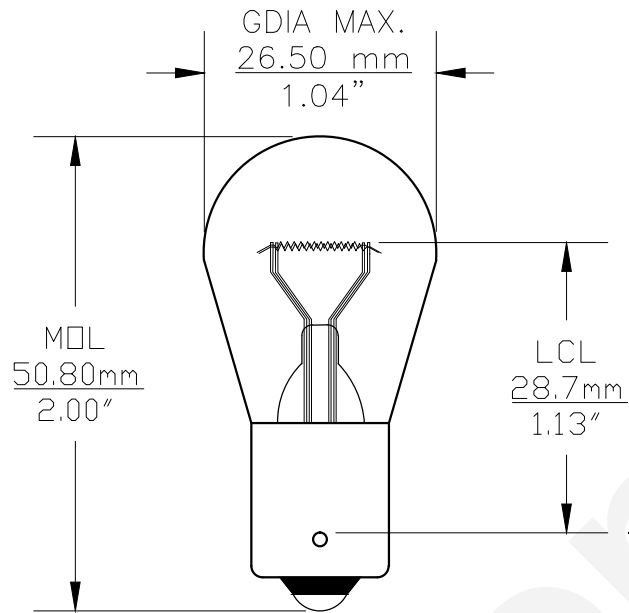

Since 1959

| PART NO. | BASE TYPE            | DESIGN VOLTS | DESIGN AMPS | MSCD   | FILAMENT TYPE | AVERAGE LIFE HOURS |
|----------|----------------------|--------------|-------------|--------|---------------|--------------------|
| 1691     | S.C. Bayonet (BA15s) | 28.0V        | 0.61±5%     | 15±10% | 2C-6          | 1000               |

| REVISIONS |                                      |            |          |
|-----------|--------------------------------------|------------|----------|
| REV #     | DESCRIPTION                          | DATE       | APPROVED |
| 1         | ISSUED                               | 02/01/2001 | E.S.     |
| 2         | UPDATED FILAMENT & MOL SPECIFICATION | 05/21/2009 | M.L.     |
| 3         | REDRAWN FOR ADDITIONAL VIEW          | 10/22/2014 | R.M.     |
| 4         | UPDATED TO CORRECT LCL               | 10/27/2016 | R.M.     |



0° VIEW

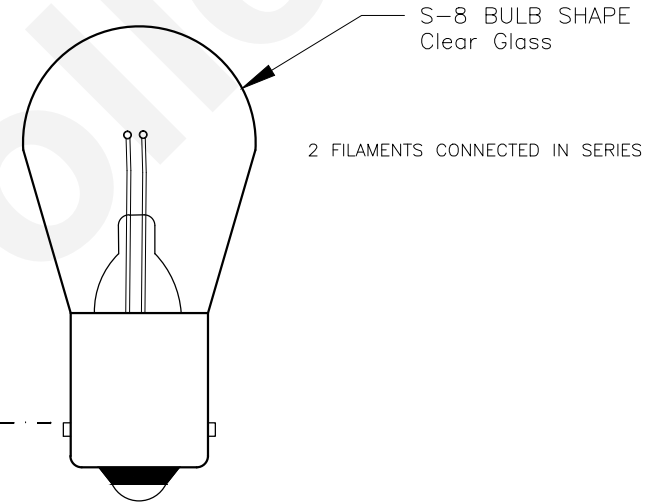

90° VIEW

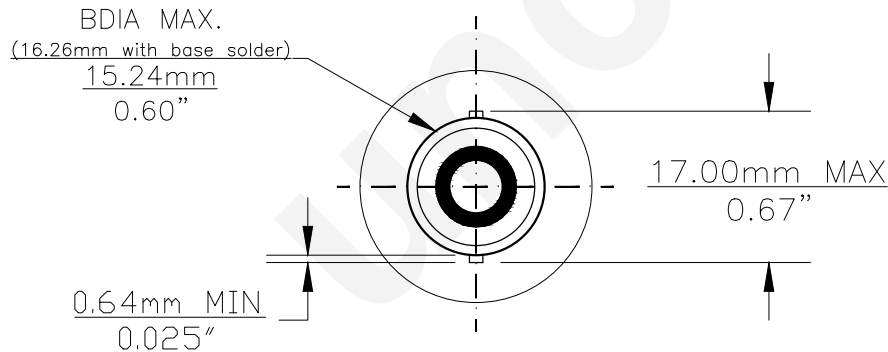

Note: Made according to SAE specifications



|   |                 |  |                               |
|---|-----------------|--|-------------------------------|
| UNLESS OTHERWISE SPECIFIED:<br>DIMENSIONS ARE IN INCHES<br>TOLERANCES |                 | CEC INDUSTRIES LTD                     |                               |
| DECIMALS  | ANGULAR         | 599 BOND STREET LINCOLNSHIRE, IL 60069 |                               |
| .XX ± .05   | ± 0.5°          | TITLE LIGHT BULB NO. 1691              |                               |
| .XXX ± .010   |                 | SIZE A                                 | FSCM NO. DWG NO. 1691         |
| FRACTIONAL  | ± 1/64          | CHECKED                                | REV 4                         |
| DRAWN ELIZABETH SONANES   | DATE 02/01/2001 | DESIGN                                 | SCALE PLOT SCALE SHEET 1 OF 1 |
| MATERIAL  |                 | FILE 1691.pdf                          | DRAWING NOT TO SCALE          |