

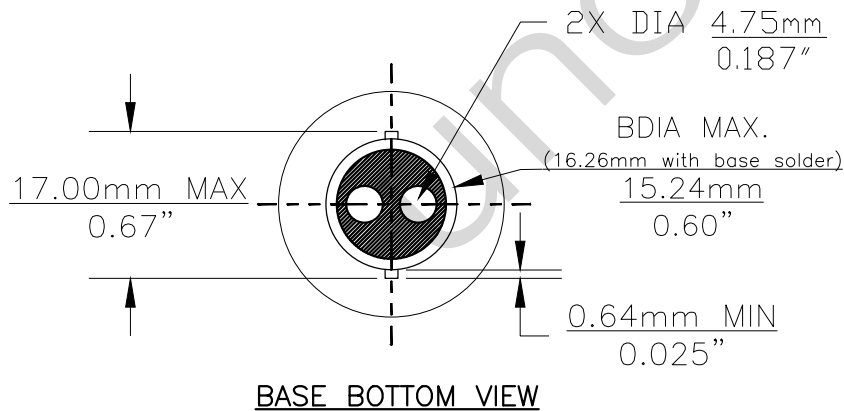

PART NO.	BASE TYPE	DESIGN VOLTS	DESIGN AMPS	MSCD	FILAMENT TYPE	AVERAGE LIFE HOURS	REVISIONS			
							REV #	DESCRIPTION	DATE	APPROVED
1157NALL	D.C. INDEX BAY15d	12.8V 14.0V	2.1 ±5% 0.59 ±8%	24±30% 2.2±30%	C-6 C-6	2000 10000	1	ISSUED	06/11/2009	D.C.

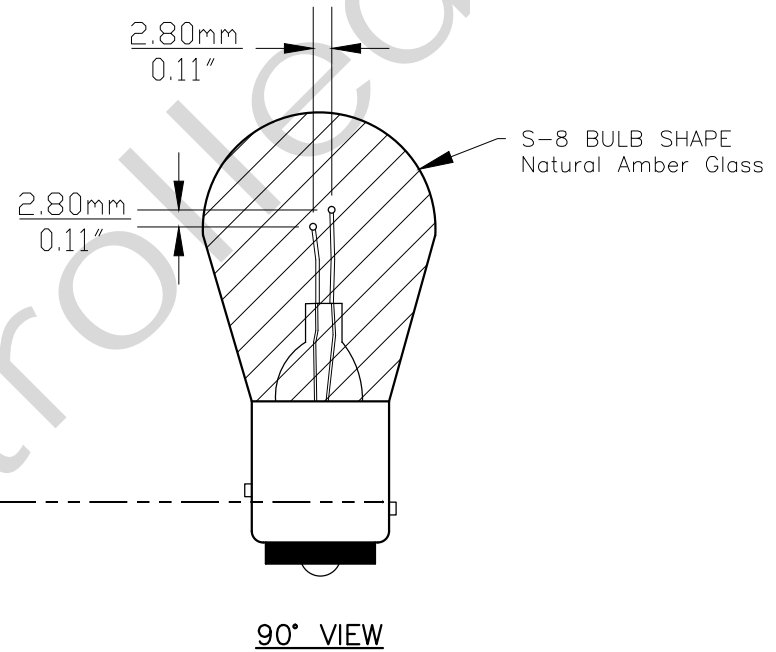
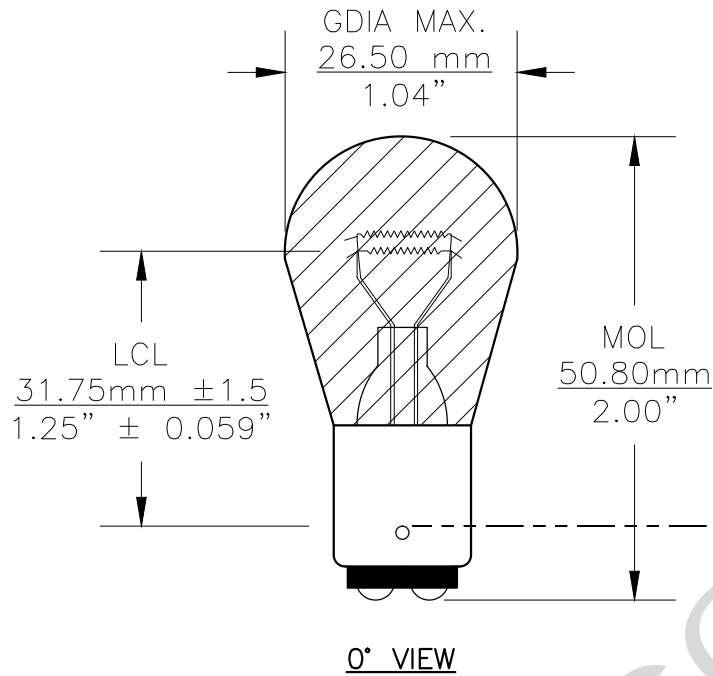

Note: Made according to SAE specifications

UNLESS OTHERWISE SPECIFIED: DIMENSIONS ARE IN INCHES TOLERANCES		CEC INDUSTRIES LTD			
DECIMALS	ANGULAR	599 BOND STREET		LINCOLNSHIRE, IL 60069	
.XX ± .05	± 0.5°	TITLE LIGHT BULB NO. 1157NALL			
.XXX ± .010		SCALE A	FSCM NO.	DWG NO. 1157NALL	REV 1
FRACTIONAL	±1/64	DESIGN	PLOT SCALE	SHEET 1 OF 1	
DRAWN D.C.		DATE 06/11/2009		MATERIAL	
CHECKED		FILE 1157NALL.pdf	DRAWING NOT TO SCALE		