

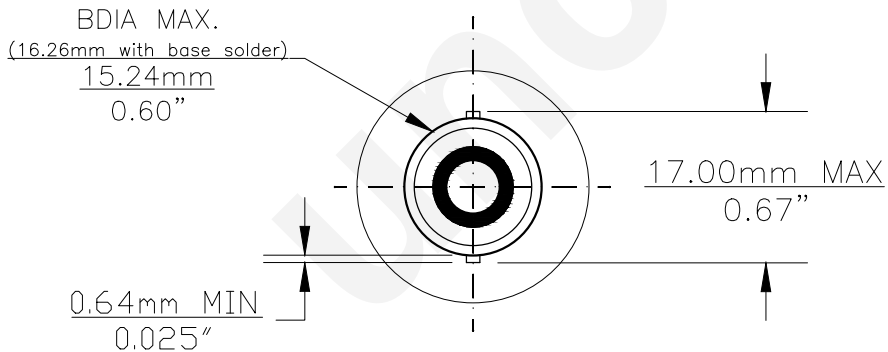

PART NO.	BASE TYPE	DESIGN VOLTS	DESIGN AMPS	MSCD	FILAMENT TYPE	AVERAGE LIFE HOURS	REVISIONS			
							REV #	DESCRIPTION	DATE	APPROVED
305	S.C. Bayonet (BA15s)	28.0V	0.51±10%	15±15%	C-2V	300	1	ISSUED	10/22/2014	R.M.
							1	CORRECTED AMPS/MSCD TOLERANCE	10/21/2016	R.M.

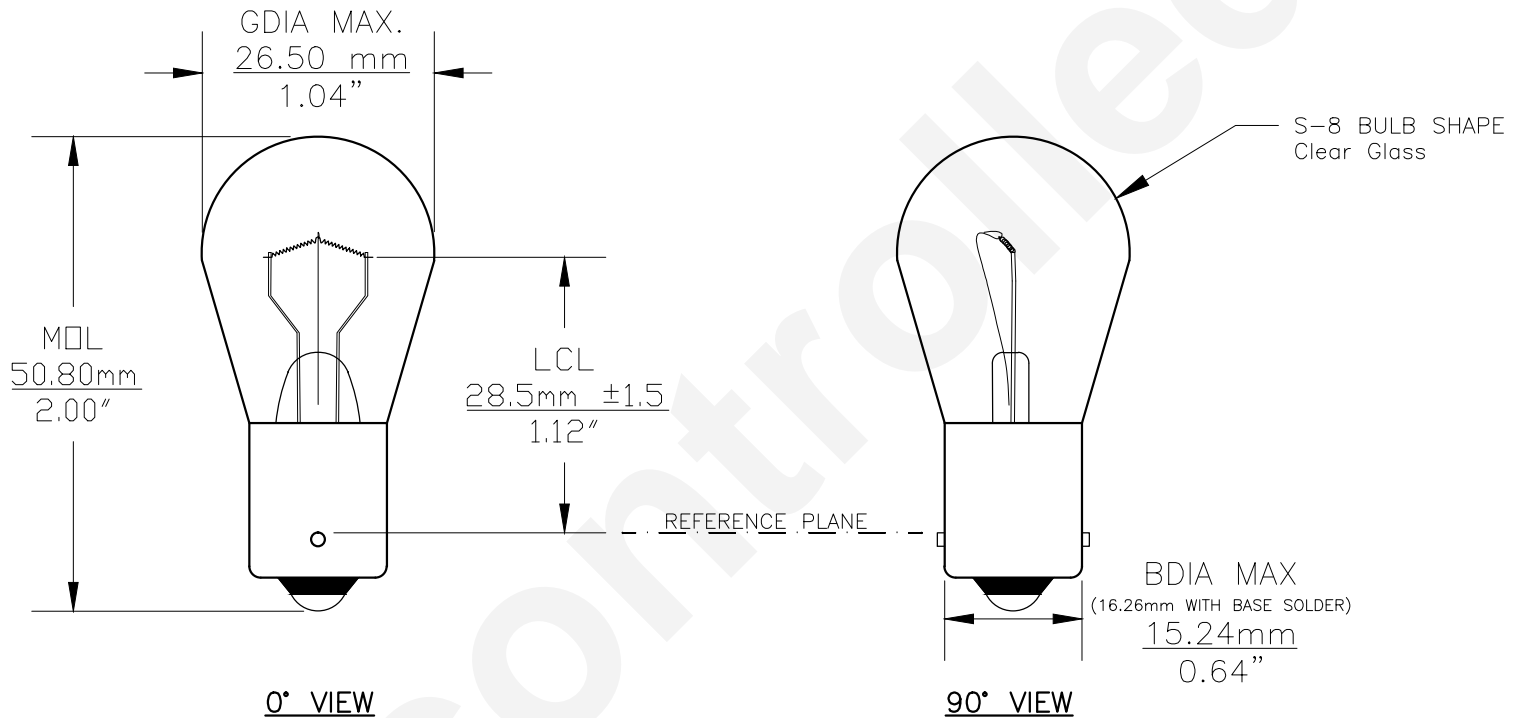

Note: Made according to SAE specifications



UNLESS OTHERWISE SPECIFIED: DIMENSIONS ARE IN INCHES TOLERANCES		CEC INDUSTRIES LTD			
DECIMALS	ANGULAR	599 BOND STREET		LINCOLNSHIRE, IL 60069	
.XX ± .05	± 0.5°				
.XXX ± .010					
FRACTIONAL	±1/64				
DRAWN ROSE MEDINA	DATE 10/22/2014	TITLE LIGHT BULB NO. 305			
CHECKED	SIZE A	FSCM NO.	DWG NO. 305	REV 2	
DESIGN	SCALE	PLOT SCALE	SHEET 1 OF 1		
MATERIAL	FILE 305.pdf	DRAWING NOT TO SCALE			