

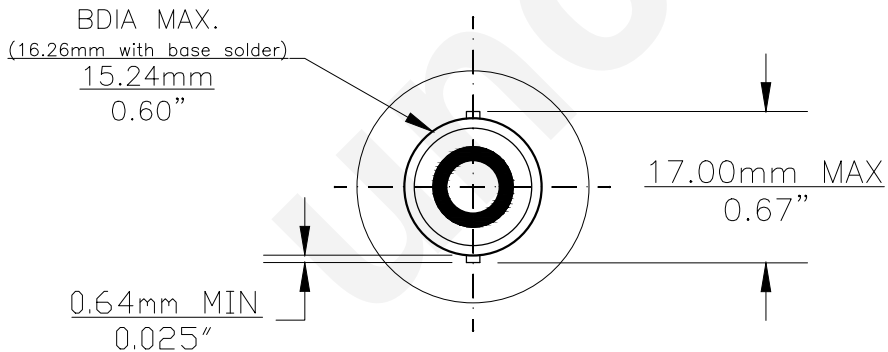

PART NO.	BASE TYPE	DESIGN VOLTS	DESIGN AMPS	MSCD	FILAMENT TYPE	AVERAGE LIFE HOURS	REVISIONS			
							REV #	DESCRIPTION	DATE	APPROVED
1250	S.C. Bayonet (BA15s)	12.8V	3.90±5%	79.9±15%	C-8Z	1400	1	ISSUED	10/24/2014	R.M.

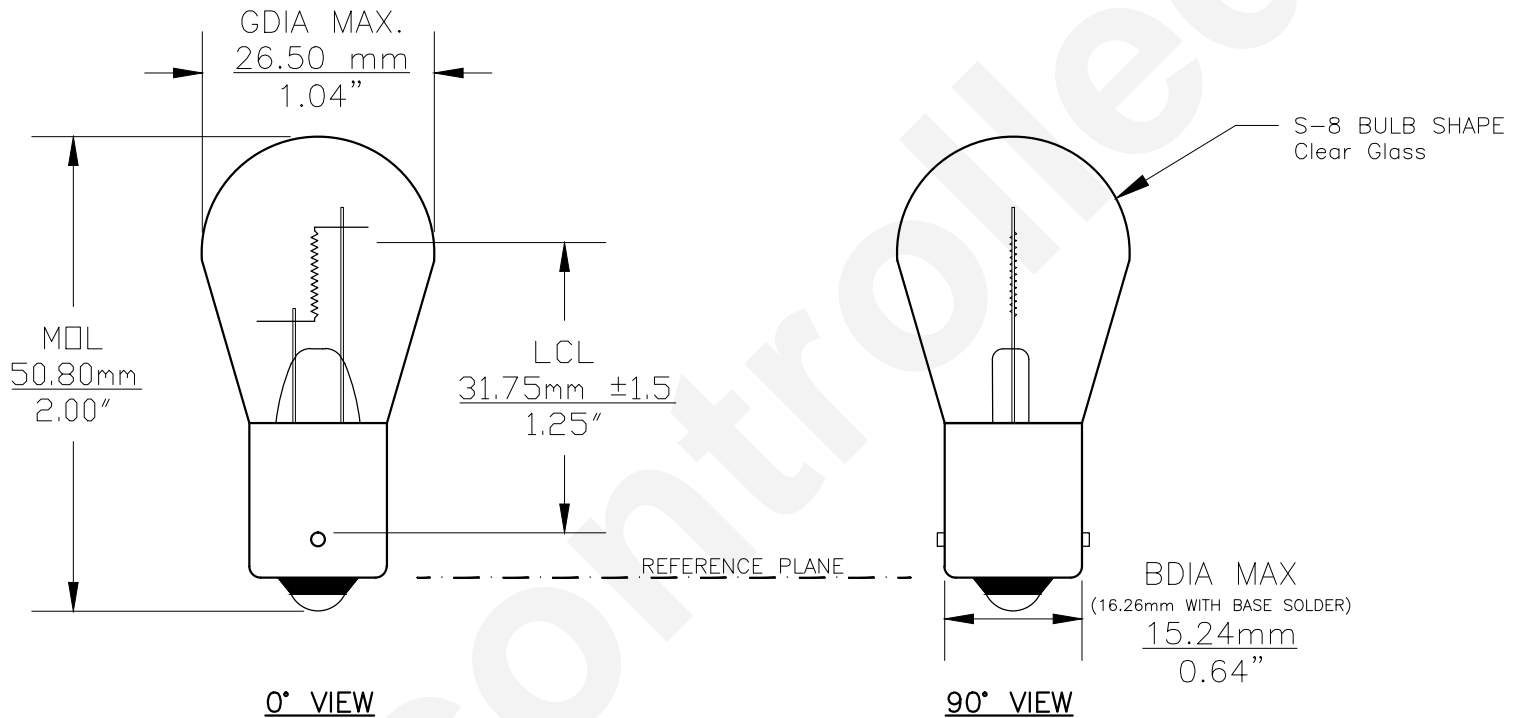

Note: Made according to SAE specifications



UNLESS OTHERWISE SPECIFIED: DIMENSIONS ARE IN INCHES TOLERANCES		CEC INDUSTRIES LTD			
DECIMALS	ANGULAR	599 BOND STREET		LINCOLNSHIRE, IL 60069	
.XX ± .05	± 0.5°	TITLE LIGHT BULB NO. 1250			
.XXX ± .010		SIZE A	FSCM NO.	DWG NO. 1250	REV 1
FRACTIONAL	± 1/64	DESIGN	SCALE	PLOT SCALE	SHEET 1 OF 1
DRAWN ROSE MEDINA DATE 10/24/2014		MATERIAL		FILE 1250.pdf	DRAWING NOT TO SCALE